

# CCTA: A Review Paper

Sarthak Grover <sup>1</sup>, Himanshu Sharma <sup>2</sup>, Gyanendra Singh <sup>3</sup>, Anmol Sharma <sup>4</sup>

B. Tech, JAYPEE Institute of Information Technology, Noida, UP<sup>1-4</sup>

**Abstract:** The CCTA (Current Conveyor Transconductance Amplifier) designed for current output signal processing in CMOS technology is reviewed in this paper. The CCTA has been brought in as the new reliable element for current mode signal processing, which should be very reliable for several applications, such as sensor generating output signals processing using CCTA. CCTA is assumed for use for the most part in current mode circuits yet it is additionally great decision if there should be an occurrence of voltage mode or potentially half and half (voltage-current) circuits (e.g. V/I converters). This modern dynamic gadget is a recently composed sort of simple piece that was built by trans impedance amplification, yet CCTA expects even significantly more adaptability in circuit applications.

**Keywords:** CCTA, Signal Processing, Applications of CCTA, CMOS based CCTA.

## I. INTRODUCTION TO CCTA

The current conveyor (CC) is the fundamental constructing block of a number of modern applications both inside the single and the combined modes. The CCTA (modern-day Conveyor Transconductance Amplifier) is the newly designed kind of analog block that become inspired via transimpedance amplifier (current feedback amplifier which is built from CCII conveyor observed with the aid of voltage buffer). CCTA is designed for usage in most cases in contemporary mode circuits however it's also exact desire in case of hybrid (voltage-modern-day) circuits. Due to the well-known benefits which include decreased distortions, low impedance, high output impedance, less effected to switching noise, higher ESD immunity, excessive slew rate and large bandwidth, the layout and implementation of modern-mode active filters the use of cutting-edge-mode lively factors [2] have come to be pretty famous for wide type of applications due to their inherent advantages over the voltage-mode counter components. The input is represented with the aid of the modern conveyor CCIII that is followed by way of double Output Transconductance of Amp (OTA). The CCTA may be moderately beneficial, for example, in contemporary sensing applications. In reality, if a contemporary, at a commonplace point into a network, needs to be sensed, the current “probe” should be able to make go with the flow a modern with very low collection impedance while the sensed output can be further processed (amplified, filtered etc.). The Current Conveyor Transconductance Amplifier (CCTA) is a pretty new element [2-3] that has inner structure based totally at the 3-generation Current Conveyor (CCIII) and multiple output based transconductance amplifier. one of the changes [6], [7] supposes that current conveyor is of the second-generation kind (CCII) like in our case. In 2006, a new lively constructing block specifically present day conveyor transconductance amplifier (CCTA) is presented for analog signal processing [8], that's suitable for a class of analog signal processing for voltage-mode and present day-mode approach. CCTA has been broadly applied in present day-mode circuit, as an example, filter and oscillator circuits.

Figure 1 shows a standard symbol of CCTA.

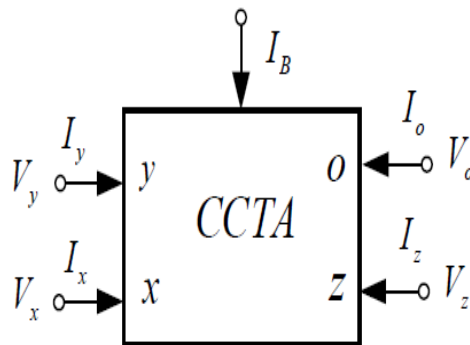

Figure. 1. Symbol of the CCTA [3]

Figure 2 shows CMOS based implementation of the CCTA block. A current processing current-tunable time-honored biquad clear out is reviewed which consists of modern-day conveyor trans-conductance amplifiers (CCTAs) and grounded capacitors. It can recognize LP, BP, HP, BR and AP in the contemporary form at excessive impedance output via appropriate choice of the enter signals, without any matching condition or behavior.

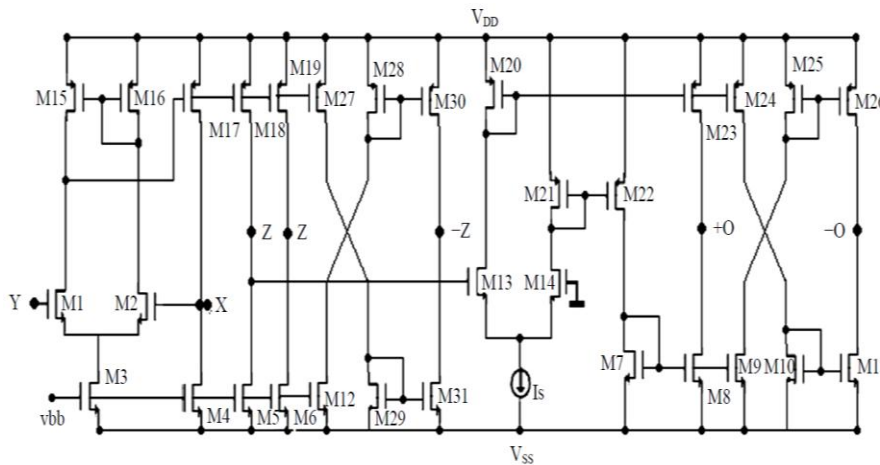

Figure 2: CMOS Implementation of CCTA [2]

## II. Applications of CCTA

The new evolved CCTA could be very versatile characteristic block which can be used in lots of diverse circuit packages. CCTA permits to be used in many well-known programs as opposed to conventional gadgets in modern in addition to in voltage mode. A number of the unique processes of the usage of this active block is shown in this section. Few applications of CCTA have been discussed here.

### 2.1 Current sensing and signal processing circuit using CCTA

The CCTA works as a via modern-day sensor even at floating ability without affecting the measured circuit and on the equal time the sensed signal is processed via best one energetic element. Whilst the  $Y_m$  and  $Z_z$  as frequency based elements then the energetic filters may be designed by means of the equal manner like with traditional opamps. Figure 3 shows the application of CCTA in current sensing and signal processing using CCTA.

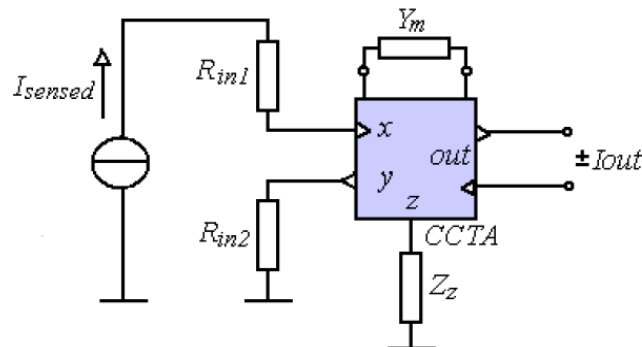

Figure 3: CCTA current sensing [3]

### 2.2 Biquadratic active band-pass filter with CCTA:

Distinctive feature of the two complementary modern outputs is the CCTA with grounded “y” terminal and infinity gain (COA behavior) absolutely corresponding to standard opamps in voltage mode. In current mode we're able to recognize by CCTA almost each known circuit with opamp in voltage mode, via simple adjoint transformation [6]. as an instance the biquadratic filter may have taken. Figure 4 shows a low pass filter which is made using CCTA.

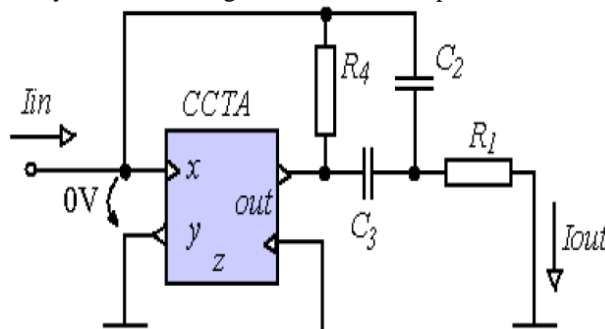

Figure 4: Low Pass Biquad Filter using CCTA [3]

### III. CONCLUSION

The new device CCTA (based on CCII input) represents, thanks to its high versatility, the new way in current signal processing. Some simple connections with CCTA were introduced here, but many further applications are possible as amplifiers, filters, oscillators, rectifiers in current as well as voltage mode. By the two current outputs is the device predetermined to be one of the best possibilities to design current mode circuits from the classical opamp ones using adjoint transformation.

### REFERENCES:

- [1] Kumar, U.: *Current Conveyors: A review of the State of the Art*. IEEE Circuits and Systems Magazine, Vol. 3, No. 1, pp. 10-13.
- [2] Sajai Vir Singh "Universal Current-Controlled Current-Mode Biquad Filter Employing MO-CCCCTAs and Grounded Capacitors" *Circuits and Systems*, 2010, 1, 35-40
- [3] Roman Prokop "New modern circuit block CCTA and some its applications" *ELECTRONICS' 2005*
- [4] Roman Prokop "NEW MODULAR CURRENT DEVICES FOR TRUE CURRENT MODE SIGNAL PROCESSING" *ELECTRONICS' 2007*
- [5] Prokop, R., Musil. V.: *CCTA – a new modern circuit block and its internal realization*, In *Electronic Devices and Systems 05-Proceedings. The 12th Electronic Devices and Systems Conference*, Brno, 2005.
- [6] Fabre, A., Saaïd, O. and Barthelemy, H.: *On the frequency limitations of the circuits based on second generation current conveyors*, *Analog Integrated Circuits & Signal Processing (AICSP)*, Special issue on current processing and current mode circuits, 2006
- [7] Biolek D., Gubek, T.: *New Circuit Elements for Current-Mode Signal Processing*, [www.elektrorevue.cz](http://www.elektrorevue.cz), 2001